

POWER POST



The Power Post brings the power directly to your bike. The Post & Ring-style rack features built-in power outlets, allowing simultaneous charging for up to two eBikes. Keep your bikes securely locked while you fill up your batteries and get ready to ride.

Also available in a non-locking, post-only version to bring power to existing bike parking such as our Stack Rack.

Product Specifications

- Two built-in grounded outlets for charging eBikes
- Access port near bottom for electrical plumbing
- Full rectangular tube construction to deter pipe cutters
- Accommodates two standard or electric bikes
- Meets APBP bike parking guidelines
- Ring-less, non-locking version can accompany existing bicycle racks to provide a charging point

Power Post

Recommended Setbacks

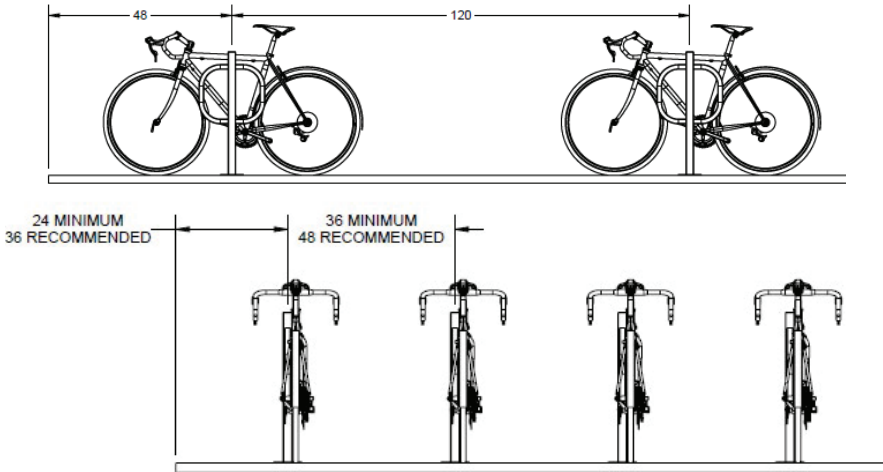

2 electric or
Standard bikes



2 x 4" laser
cut tube upright
1.25" lock ring



Powder coat
zinc-plated



Temporary: 28879
Temporary Secure: 26270
Permanent
Spike Anchor: 6266



1 year
warranty



Made in
the USA

Anchors sold separately

Dimensions

Locking Power Post

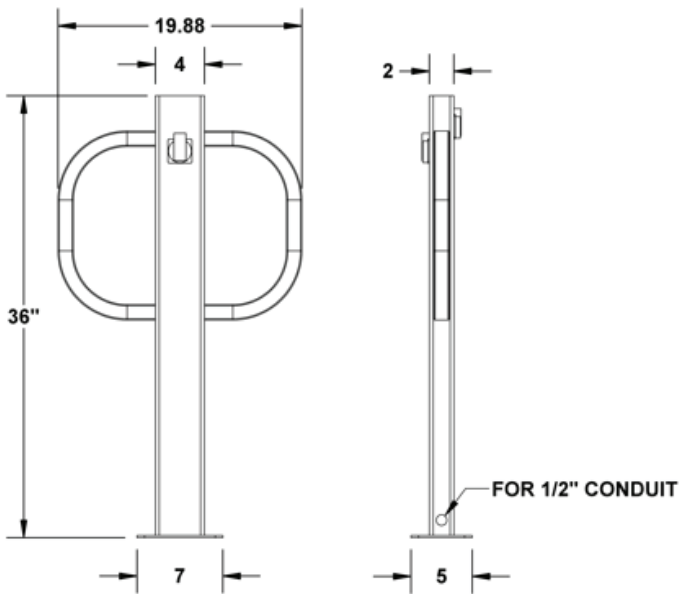

Non-locking Power Post

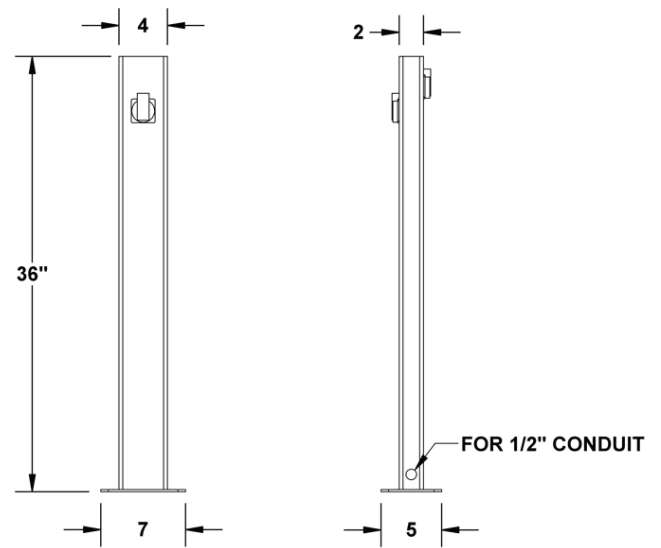

| Model | Finish | Weight | Length | Height | Width |
|----------------------------------|-------------|---------|--------|--------|-------|
| Power Post with Lock Ring | | | | | |
| 34102 | Powder Coat | 22 lbs. | 19.88" | 36" | 5" |
| 34015 | Zinc Plated | 22 lbs. | 19.88" | 36" | 5" |
| Power Post , Non-locking | | | | | |
| 34206 | Powder Coat | 16 lbs. | 7" | 36" | 5" |
| 34014 | Zinc Plated | 16 lbs. | 7" | 36" | 5" |

Design files and additional product resources available
online at sarisinfrastructure.com