

eBike CHARGING STATION



Our eBike Charging Station is a public-use, universal eBike battery charging system that also provides a secure means of parking your bike. Designed to accommodate a wide range of personal eBike drive systems, each "charging dock" has a secure, user-accessible locker that contains a 120V/240V outlet for power access. Using their personal charger, users can safely store the charger inside the locker during charging.

Product Specifications

- Available in worldwide power options 120V/240V; designed to be hardwired
- All units equipped with GFCI outlets
- Charging box door secured with padlock
- Active cooling system to prevent charger from overheating
- Can be installed indoors or outdoors with overhead protection
- User instructions on each unit
- Optional wheel tray accessory can accommodate up to 5" fat tires
- All electronic components UL/CE listed

eBike Charging Station

Site Layout

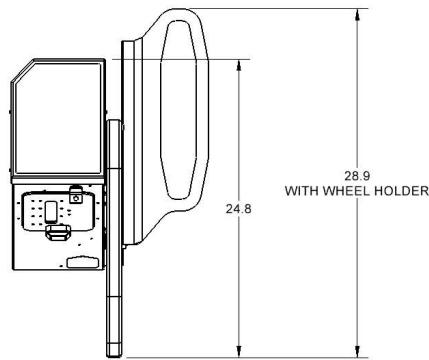
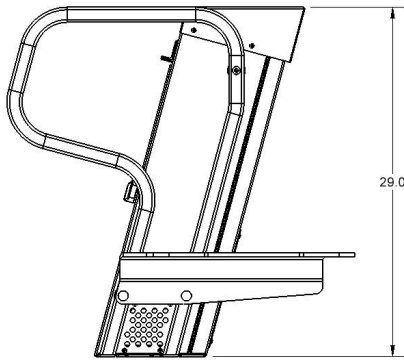
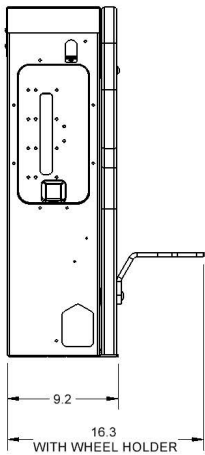
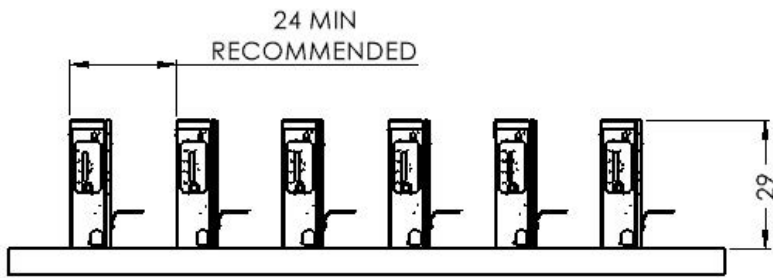
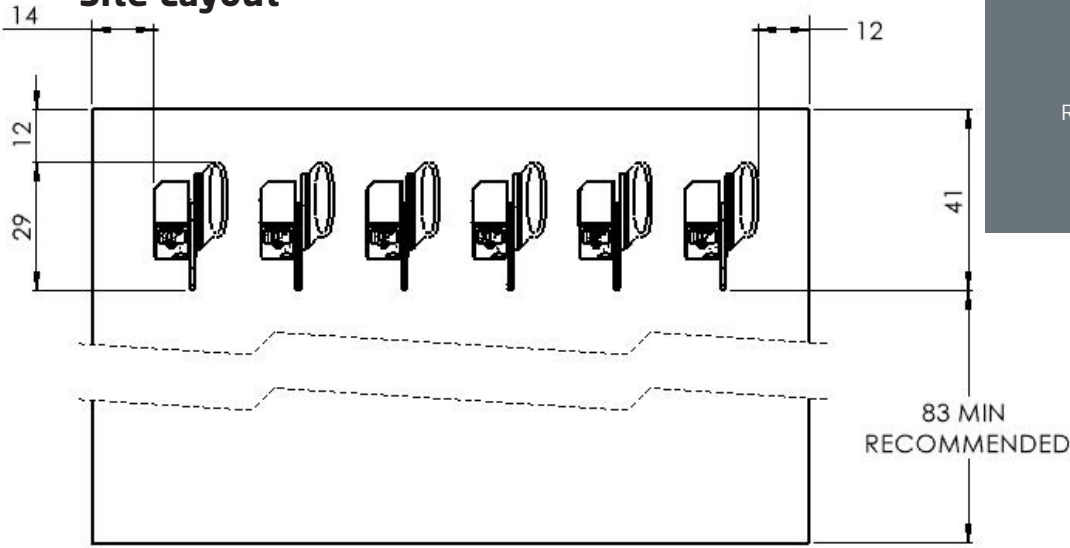

User Instruction included on each unit

Part No.	Outlet configuration
84101320	USA/Canada Outlet
84201320	EU Outlet
84301320	UK Outlet
84401320	Australia/New Zealand Outlet



one Bike per charging dock



Can be installed indoors or outdoors with overhead cover



Recommended anchor: #28879



1 year warranty



Made in the USA



Downloadable product resources available online:



CAD Files



SketchUp Files



Written Specs



Photos